

Caster Wheel Kit (TK95055)

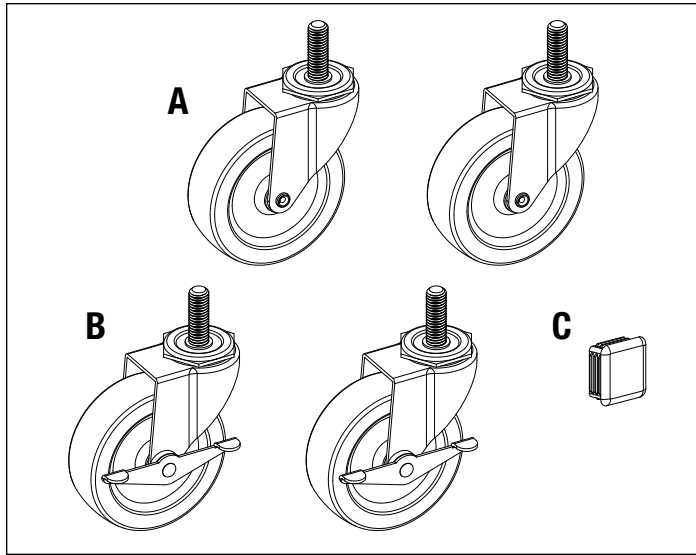

The Caster Wheel Kit provides four wheels (two with brakes) to simplify attachment and removal of a TKV 20 Material Collection System.



Kit Includes

	Description	Qty.
A	Caster Wheel without Brake	2
B	Caster Wheel with Brake	2
C	Plastic End Cap	4
D	1/2" Flange Nut	8



CAUTION: Always use the brakes on the Caster Wheels after wheeling the TKV 20 into your desired location. Failure to use these brakes can result in damage to equipment and serious injury.



WARNING: Do not disconnect the TKV 20 from the tractor's 3-point arms while material is inside of the hopper. Damage can occur to the TKV 20's storage stands as well as these Caster Wheels.

Installation Instructions

1. While attached to the tractor, lift the TKV 20 up with the 3-point arms.
2. Disconnect the wire lock pins that secure each storage stand to its storage channel on the left and right of the TKV 20.

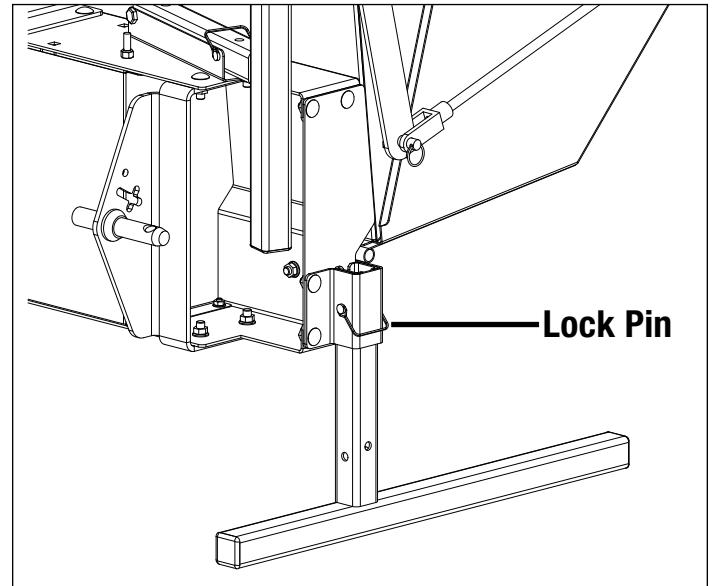

3. With the storage stands removed, remove the Plastic End Caps (C) from the end of each stand. These caps can be difficult to remove without causing damage. The Plastic End Caps in this kit can replace these existing caps in step 8.

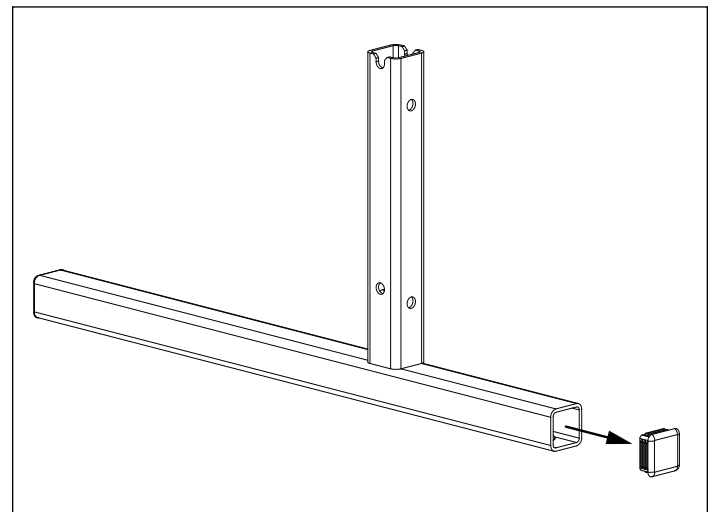

4. Thread one 1/2" Flange Nut (D) onto each Caster Wheel (B, D) with the nut's flange facing upwards.

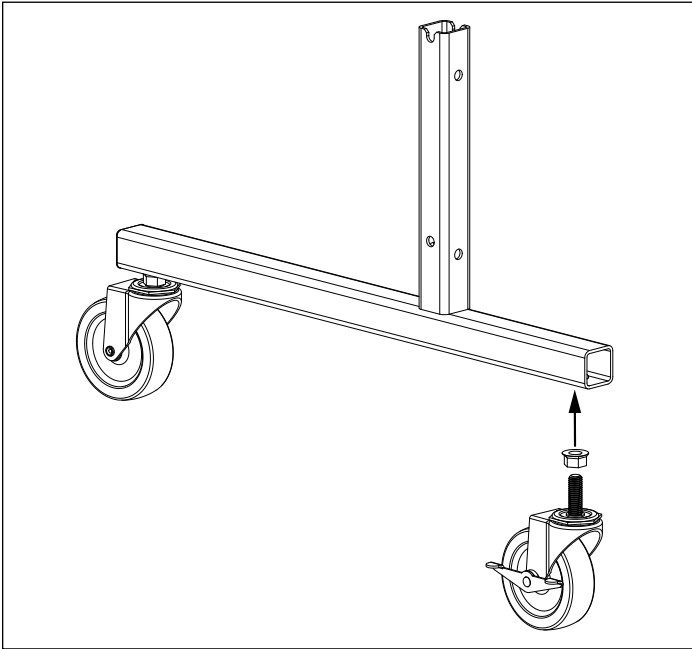

5. Determine which end of the storage stands you want to install the Caster Wheels with Brakes (B) in. Both wheels can be installed on the front or rear of each storage stand. Do not install both of these wheels on the same storage stand.
6. Position a Flange Nut (D) over the hole inside the tube of a storage stand. Using your other hand, thread a caster wheel (A, B) through the hole on the bottom of the storage stand into the Flange Nut being held on the inside of the storage stand. Thread until tight. Repeat for the other three Caster Wheels.
7. To tighten each Caster Wheel in place, turn the the Flange Nuts that are underneath the storage stands (installed in step 4).

8. Reinstall the Plastic End Caps (C) on the ends of both storage stand. To assist with installing these, a rubber mallet can be used. Alternatively, these End Caps can be placed on a hard surface while the end of each storage stand is pushed onto them.

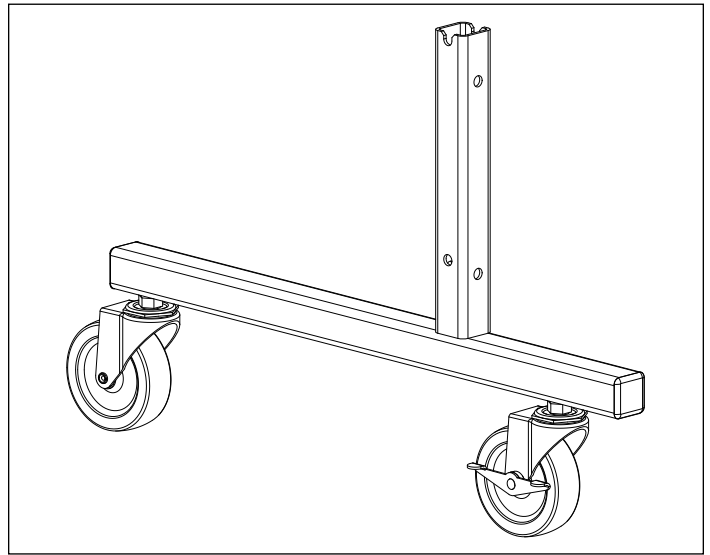

9. Reinstall the storage stands on the TKV 20.

Warranty

TerraKing's products are guaranteed to be free from defects in material and/or workmanship and to perform as advertised when properly assembled, installed, used, and maintained in accordance with written instructions. Failure to adhere to this will void the warranty. TerraKing will not be responsible for labor, loss, or consequential damage of any kind or character caused by defective parts, or for charges incurred in the replacement or repair of defective parts. TerraKing reserves the right to request photos or return of damaged/defective parts. To submit a claim, please have your original purchase date and a copy of your receipt (if available).

Warranty Period

The TerraKing Caster Wheel Kit is warranted for a period of 1 (one) year after the purchase date for residential use, and 6 (six) months after the purchase date for commercial use. This product is warranted by TerraKing to the original purchaser/customer against defects in material and workmanship under normal operating conditions.